Section 11

BASIC VEHICLE CONTROL SKILLS TEST



**THIS SECTION WILL ASSIST ALL COMMERCIAL DRIVERS
IN TAKING THE BASIC VEHICLE CONTROL SKILLS TEST**

SECTION 11: BASIC VEHICLE CONTROL SKILLS TEST

THIS SECTION COVERS

- *Skills Test Exercises*
- *Skills Test Scoring*

The basic control skills test is composed of methods and procedures which enable the examiner to determine the applicants ability to control the vehicle and judge the position of the vehicle in relationship to other objects. Your basic control skills could be tested using one or more of the following exercises off-road depending on the layout of the test site:

- Forward stop.
- Straight line backing.
- Alley dock.
- Parallel park (*driver side*).
- Parallel park (*conventional*).
- Right turn.
- Backward serpentine.

These exercises are shown in figures 11-1 through 11-7.

11.1 SCORING

CROSSING BOUNDARIES

The examiner will score the number of times you touch or cross over an exercise boundary line with any portion of your vehicle. Each encroachment will count as an error.

PULL-UPS

In some of the exercises, the examiner will also score the number of times you stop and change direction or pull-up during the exercise. Errors will be explained to you prior to the beginning of each exercise.

11.2 EXERCISES

FORWARD STOP

You may be asked to drive forward between two rows of cones and bring your vehicle to a complete stop as close as you can to the exercise boundary marked by an end line or set of cones (*without going beyond the line or cones*). (See figure 11-1).

STRAIGHT LINE BACKING

You may be asked to back your vehicle in a straight line between two rows of cones without touching or crossing over the exercise boundaries. (See figure 11-2.)

ALLEY DOCK

You may be asked to sight-side back your vehicle into an alley, bringing the rear of your vehicle as close as possible to the rear of the alley without going beyond the exercise boundary marked by a line or row of cones. (See figure 11-3.)

PARALLEL PARK (DRIVER SIDE)

You may be asked to park in a parallel parking space that is on your left. You are to drive past the parking space and back into it bringing the rear of your vehicle as close as possible to the rear of the space without crossing side or rear boundaries marked by cones. You are to try to get your vehicle (or trailer, if combination vehicle) completely into the space. (See figure 11-4.)

PARALLEL PARK (CONVENTIONAL)

You may be asked to park in a parallel parking space that is on your right. You are to drive past the parking space and back into it bringing the rear of your vehicle as close as possible to the rear of the space without crossing side or rear boundaries marked by cones. You are to try to get your vehicle (or trailer, if combination vehicle) completely into the space. (See figure 11-5.)

RIGHT TURN

You may be asked to drive forward and make a right turn around a cone. You should try to bring the right rear wheel(s) of your vehicle as close to the base of the cone as possible without hitting it. (See figure 11-6.)

BACKWARD SERPENTINE

You may be asked to back your vehicle through a 3-cone serpentine without touching any cones or crossing over the exercise (side) boundaries marked by cones. (See figure 11-7.)

Remember: If you fail either the Pre-Trip Vehicle Inspection or the Basic Control Skills Test, it is at the discretion of the examiner to administer the road test.

Figure 11-1
Forward Stop

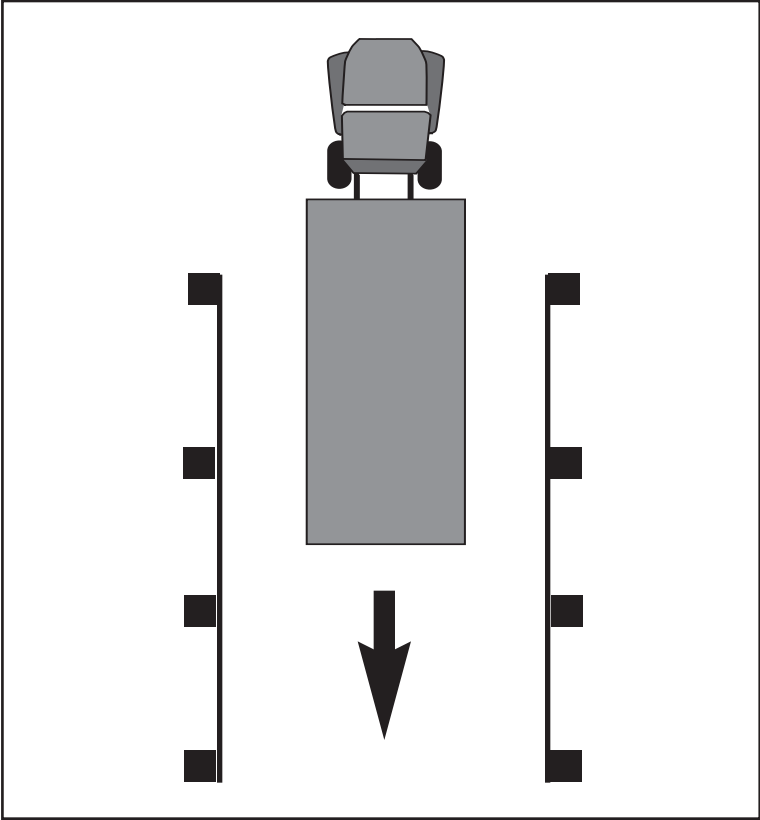
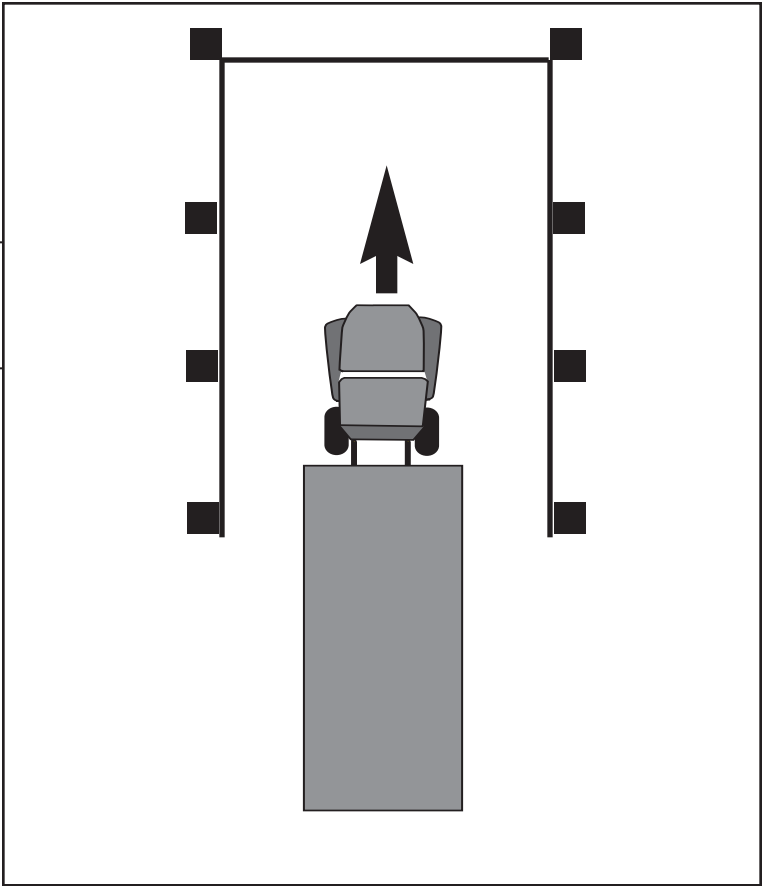

Figure 11-2
Straight Line Backing

Figure 11-3
Alley Dock

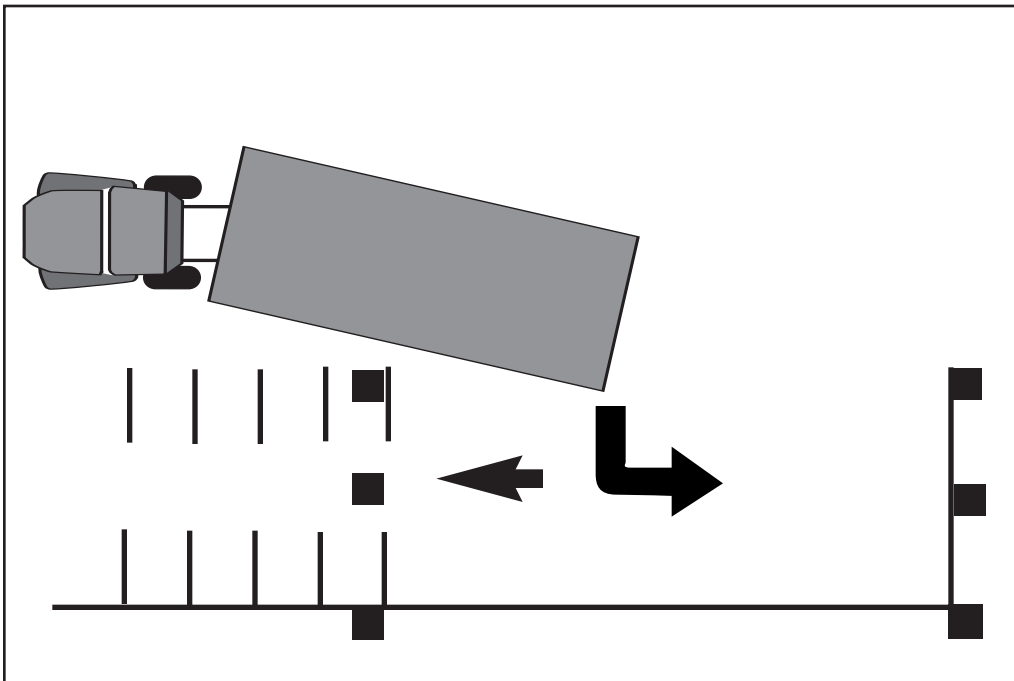
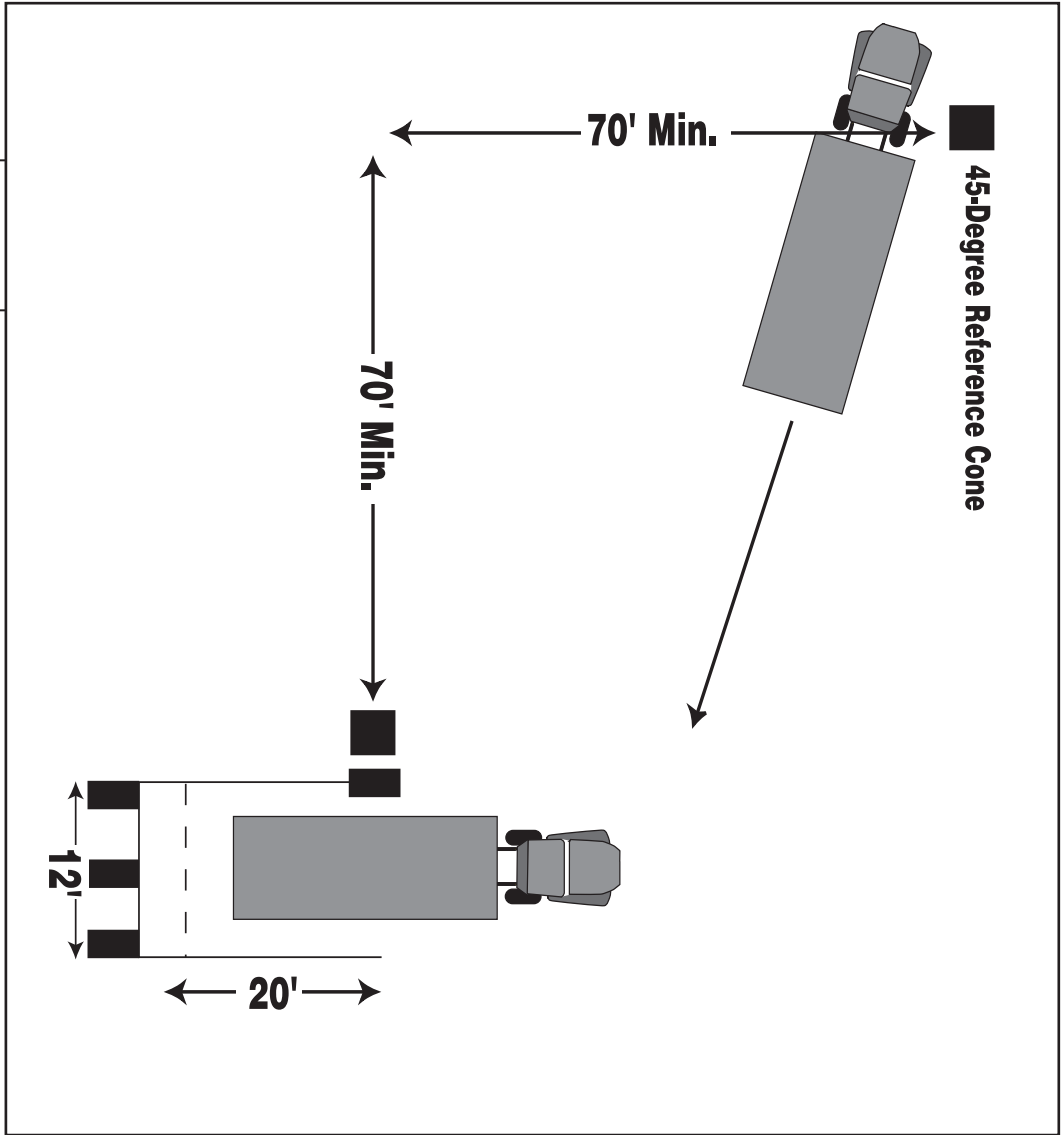

Figure 11-4
Parallel Park
(Driver Side)

Figure 11-5
Parallel Park
(Conventional)

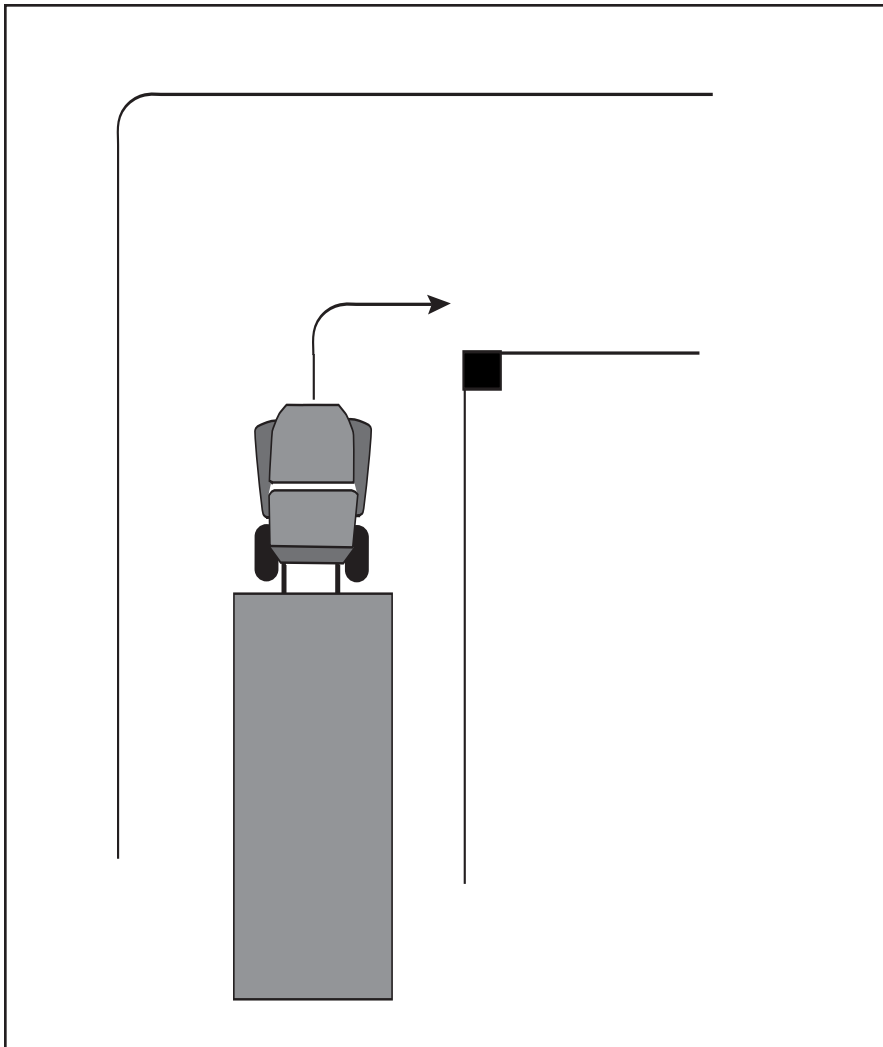
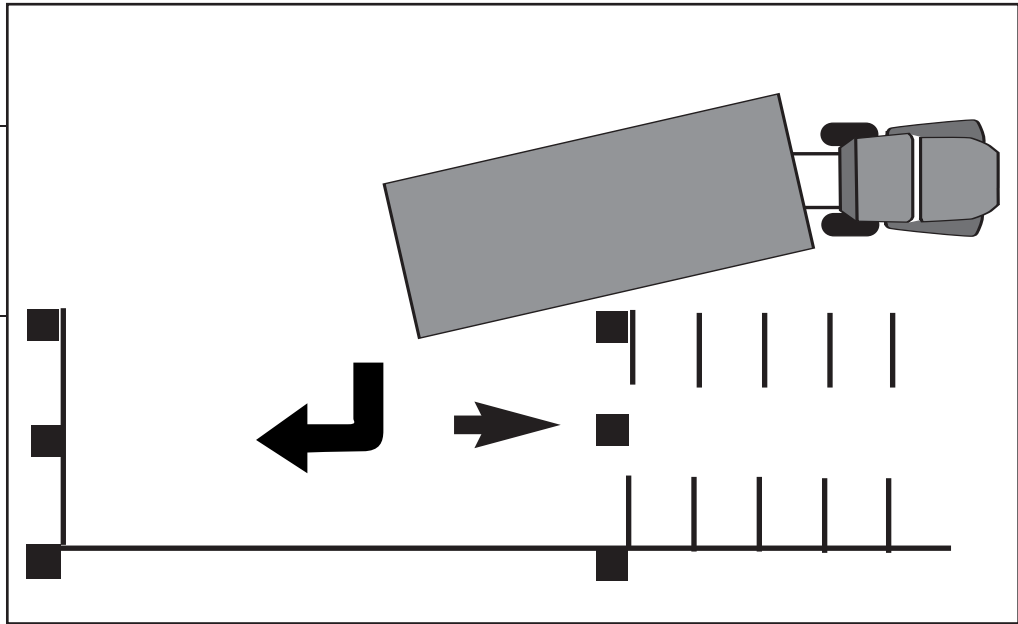

Figure 11-6
Right Turn

Figure 11-7
Backward Serpentine

